

QST BAS2 C

QUEST Tap Range Quest 2 Handled Basin Mixer With Clicker Waste Chrome



Specification

Product Type:	Taps
Main Construction Material:	Brass
Mount Type:	Deck
Handle Type:	Lever
Connection Inlet:	M10 x 265mm Copper Tails
Connection Outlet:	Flow Straightener
Number of Tap Holes:	1
Valve/Cartridge Type:	1/4 Turn 1/2" Ceramic Disc Valve
Plumbing System Requirements:	Suitable for all plumbing systems
Minimum Dynamic Pressure (bar):	0.2 bar
Maximum Dynamic Pressure (bar):	5.0 bar
Maximum Hot Water Temperature °C:	65°C
Maximum Static Pressure (bar):	10 bar
Flow Type:	Single
Isolation Included:	No

Features:

- Long life ceramic cartridge for added durability and ease of use
- Metal fixing nut for added durability
- Easy to use metal handles
- Includes clicker waste

Product Certifications:

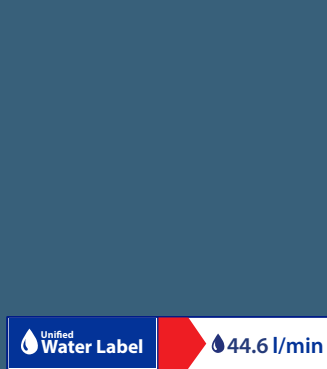

For more products, visit our website:
<http://www.bristan.com>



Dimensions (measurements in mm)

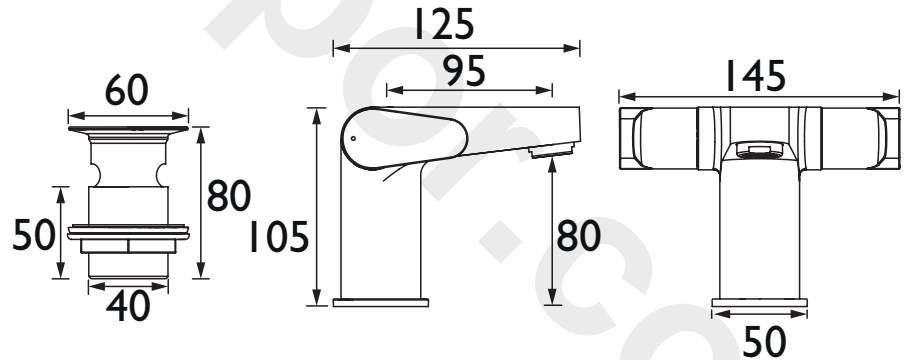

Flow Rates (l/min)

System Pressure (bar)	0.2	0.5	1	2	3	5
QST BAS2 C (mixed)	11.5	18.2	25.7	36.4	44.6	57.6

TECHNICAL DATA SHEET



BRISTAN

D9